

Transducer Vacuum Gauge Series

Vacuum components

Capacitance Gauge
Pirani Gauge
Cold Cathode Gauge
Cold Cathode Pirani Gauge
Ion Gauge
Crystal Ion Gauge



Excellent cost performance

Transducer Vacuum Gauge Series

Summary

Transducer vacuum gauges that can handle a wide range of pressures from atmospheric pressure to 10^{-8} Pa.

These vacuum gauges can be used in various industries as well as R&D, including cutting-edge semiconductor and flat panel manufacturing equipment.

They offer excellent cost performance with their compact design and reduced wiring demands, and are environmentally friendly, achieving a CE marking*¹ and RoHS compliance.

Features

- A lineup of vacuum gauges with various features
- Covers a wide range from atmospheric pressure up to 10^{-8} Pa
- Combined sensor and control unit is compact and reduces wiring needs
- A lineup with various output types to meet the demands of your application
- A line up of displays to meet the demands of your application (compatible with all models)
- CE marking , RoHS compliant

Applications

Supports a wide range of measurements from R&D to industrial equipment

- Semiconductor manufacturing equipment
- electronic component manufacturing equipment
- Accelerator-related equipment
- Space chambers
- Electron beam equipment
- Various analyzers
- Other vacuum devices
- Food products , Medical applications

Gauge name		Pa			
		10^{-8}	10^{-7}	10^{-6}	10^{-5}
Capacitance Gauge M-342DG	133.3 kPa				
	13.33 kPa				
	1.333 kPa				
	133.3 Pa				
	13.33 Pa				
Pirani Gauge M-350PG / M-351PG					
Cold Cathode Gauge M-370CG					
Cold Cathode Pirani Gauge M-361CP					
Ion Gauge M-311HG					
Crystal Ion Gauge M-338MX					



Measurement pressure range										Features
10^{-4}	10^{-3}	10^{-2}	10^{-1}	1	10^1	10^2	10^3	10^4	10^5	
										<ul style="list-style-type: none"> • High-precision and stable absolute pressure measurement • Compact, low power consumption
										<ul style="list-style-type: none"> • Light and compact, low-cost • Supports a wide range of applications
										<ul style="list-style-type: none"> • Handles a wide range of processes • Low maintenance costs
										<ul style="list-style-type: none"> • Reduce costs with a dual-purpose device • Handles a wide range of processes
										<ul style="list-style-type: none"> • Trustworthy sensors with proven performance • High-precision pressure measurement
										<ul style="list-style-type: none"> • Reduce costs with a dual-purpose device • High-precision pressure measurement • Atmospheric pressure sensor function • Filament lifespan detection feature (optional)

Capacitance Gauge

M-342DG

CE

RoHS

Summary

This temperature-corrected diaphragm vacuum gauge can measure absolute pressure stably with high precision, as the impact of the external environment is minimized through the use of a small-sized silicon MEMS chip in the pressure sensor.

Features

- High precision, stable pressure measurement
 - Excellent zero point stability
 - Low temperature dependence
 - Excellent vibration resistance
- Compact and low power consumption
 - Weight 200 g. Size W46 mm × H49 mm × L106 mm compact, lightweight ^{※1}
 - ※1:Size and weight of the coupling NW16 specifications
 - Power consumption 0.5 W



※ Not suitable for applications where corrosive gas is used.
Please consult us for details.

Specifications

Type	Capacitance Gauge				
	M-342DG-1D	M-342DG-1N	M-342DG-11	M-342DG-12	M-342DG-13
Full Scale Pressure (Pa)	13.33	133.3	1.333 k	13.33 k	133.3 k
Accuracy (% of reading)	0.20 (at 23°C)				
Zero Temperature Coefficient (% of full-scale/°C)	0.01	0.005	0.002		
Span Temperature Coefficient (% of reading/°C)	0.01		0.005		
Resolution (% of full-scale)	0.01	0.005			
Lowest Reading (% of full-scale)	0.01				
Lowest Suggested Pressure for Reading (% of full-scale)	0.05				
Lowest Suggested Pressure for Control (% of full-scale)	0.5				
Response Time (ms)	100	30			
Pressure Limit	200 kPa (However, the internal pressure of NW16 and NW25 must not become positive.) *130 kPa (Absolute pressure) for M-342DG-1D type				
Input Voltage (VDC)	+13.5 ~ 26.4				
Power Consumption (W)	0.5				
Analog Output (VDC)	0 ~ 10				
I/O connector	D-sub 9 pin male (mating screw: #4-40 inch)				
Maximum Cable Length (m)	100 (0.3 mm ²)				
Zero Adjustment Methods	Push Switch / Remote				
Operating Temperature/ Storage Temperature (°C)	0 ~ 50 / -20 ~ 70 (Not operating)				
Gas contacting part material	Stainless steel, Si, Glass, Fluorine Rubber				
Dimensions (mm)	105.8 × 48.9 × 46 (NW25)				
Fitting Type, Weight	NW16 (200 g), NW25 (210 g), 8-VCR Fimele (250 g), φ 70ICF (460 g)				
Conformity	CE marking, RoHS, IP40				

■ Dimensions diagram

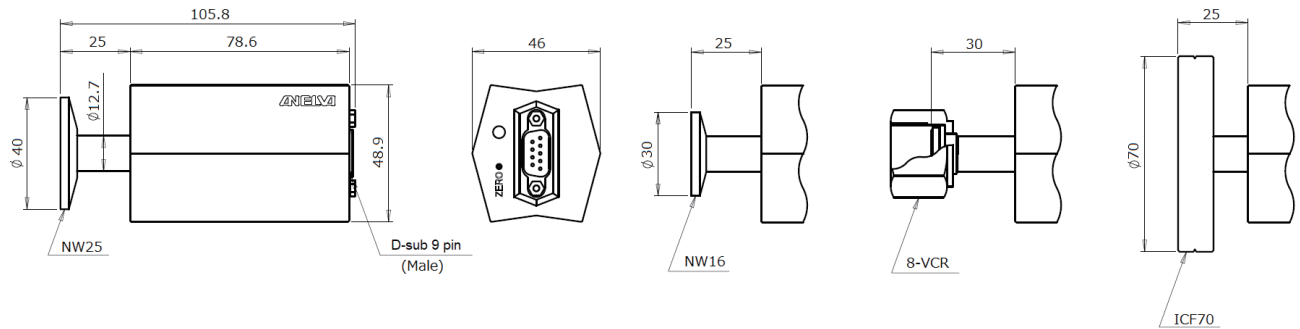

■ Ordering information

Part Number	Model	Discription	Remarks	Code
8B1-0011-240	M-342DG-1D-N16	Capacitance Gauge (13.33 Pa)	With NW16 flange	22735
8B1-0011-241	M-342DG-1D-N25		With NW25 flange	22736
8B1-0011-242	M-342DG-1D-C70		With ϕ 70ICF flange	22737
8B1-0011-243	M-342DG-1D-VC8		With 8-VCR (Fimele)	22738
8B1-0011-206	M-342DG-1N-N16		With NW16 flange	22710
8B1-0011-207	M-342DG-1N-N25	Capacitance Gauge (133.3 Pa)	With NW25 flange	22711
8B1-0011-208	M-342DG-1N-C70		With ϕ 70ICF flange	22712
8B1-0011-209	M-342DG-1N-VC8		With 8-VCR (Fimele)	22713
8B1-0011-193	M-342DG-11-N16		With NW16 flange	22715
8B1-0011-194	M-342DG-11-N25	Capacitance Gauge (1.333 kPa)	With NW25 flange	22716
8B1-0011-195	M-342DG-11-C70		With ϕ 70ICF flange	22717
8B1-0011-196	M-342DG-11-VC8		With 8-VCR (Fimele)	22718
8B1-0011-173	M-342DG-12-N16		With NW16 flange	22720
8B1-0011-174	M-342DG-12-N25	Capacitance Gauge (13.33 kPa)	With NW25 flange	22721
8B1-0011-166	M-342DG-12-C70		With ϕ 70ICF flange	22722
8B1-0011-175	M-342DG-12-VC8		With 8-VCR (Fimele)	22723
8B1-0011-168	M-342DG-13-N16		With NW16 flange	22725
8B1-0011-169	M-342DG-13-N25	Capacitance Gauge (133.3 kPa)	With NW25 flange	22726
8B1-0011-170	M-342DG-13-C70		With ϕ 70ICF flange	22727
8B1-0011-171	M-342DG-13-VC8		With 8-VCR (Fimele)	22728

Pirani Gauge

M-350PG / M-351PG

CE

RoHS

Summary

Light, compact and low-cost, measures from atmospheric pressure to 10^{-2} and is suitable for a wide range of applications.

Features

- Light and compact, low-cost
- 2 types of filaments are available (M-350: tungsten, M-351: nickel)
- Replaceable sensor



Specifications

Type	Pirani Gauge			
	M-350PG-SD Standard Type	M-350PG-SP Type with Set Point	M-350PG-RS RS485 Type ^{※1}	M-351PG-SP Nickel filament Type with Set Point
Pressure measurement range	$5 \times 10^{-2} \sim 1 \times 10^5$ Pa			
Accuracy	$\pm 50\%$: $5 \times 10^{-2} \sim 1 \times 10^{-1}$ Pa $\pm 15\%$: $1 \times 10^{-1} \sim 1 \times 10^4$ Pa $\pm 50\%$: $1 \times 10^4 \sim 1 \times 10^5$ Pa			
Repeatability	$\pm 2\%$: $1 \times 10^{-1} \sim 1 \times 10^4$ Pa			
Input voltage	DC+14 ~ 30 V			
Power consumption	1 W			2 W
Analog output	0 ~ 10 V		—	0 ~ 10 V
Set point	—	2 Contact Output (1A 30V DC)		
Interface	—		RS485	—
I/O connector	D-sub 9 pin (Pin type)			
Maximum cable length	200 m (0.34 mm ²) ^{※2}			
Zero points adjustment	Push switch			
Operating Temperature	5 ~ 60°C			
Storage Temperature	-20 ~ 70°C (at no operation)			
Sensor allowable temperature range	O-ring Type : 150°C MAX (Without Electronics) Metal seal type : 300°C MAX			
Allowed overload pressure	1MPa (limited to coupler shape NPT and inert gas, absolute Pressure)			
Suitable sensor	MP1			MP2
Sensor material (main component)	Filament	Tungsten		Nickel
	Case	Stainless steel		
	Insulator	Kovar glass		Kovar glass+Al ₂ O ₃ coated
Dimensions	88.5 × 40 × 23 mm (NW25) Note: The outer dimensions of the flange are excluded			
Flange shape	NW16, NW25, ϕ 34 ICF, 1/8NPT, ϕ 15 Gauge Port, ϕ 18 Gauge Port			NW16, NW25, 1/8NPT
Weight	M-350PG / 351PG-SP NW16 (81 g), NW25 (96 g), 1/8NPT (73 g)			
Conformity	CE marking , RoHS , IP40			

※1 The RS485 type is not compatible with the M-601/603GC display.

※2 The maximum length of the gauge cable is 100m when connecting an M-601/603GC display unit.

■ Dimensions diagram

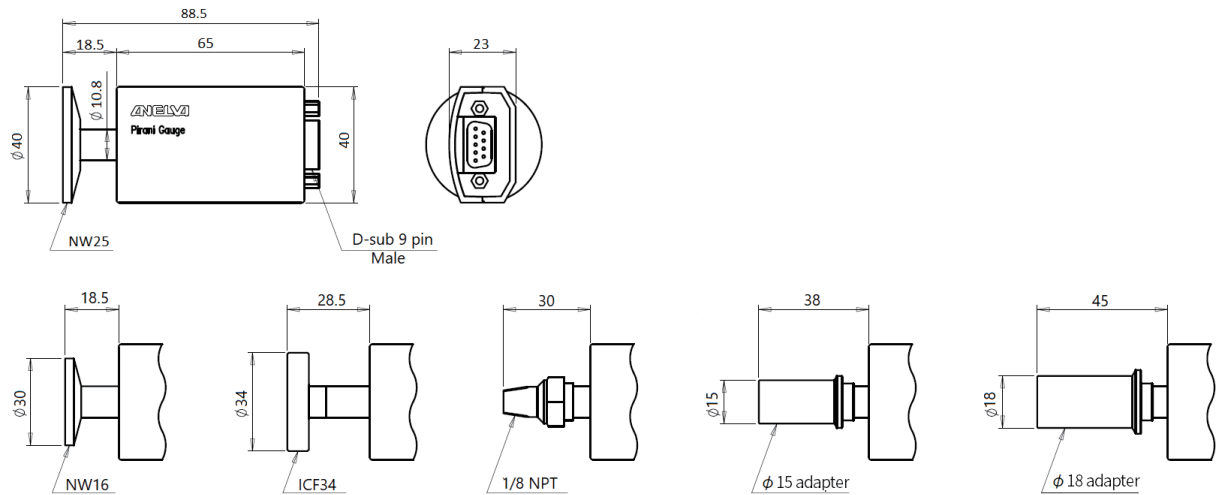

■ Ordering information

Parts Number	Model	Description	Remarks	Code
8B1-0010-835	M-350PG-SD/N16	Pirani Gauge	With NW16 flange	22500
8B1-0010-836	M-350PG-SD/N25	Pirani Gauge	With NW25 flange	22501
8B1-0010-837	M-350PG-SD/P15	Pirani Gauge	For ϕ 15 gauge port	22502
8B1-0010-838	M-350PG-SD/P18	Pirani Gauge	For ϕ 18 gauge port	22503
8B1-0010-883	M-350PG-SD/C34	Pirani Gauge	With ϕ 34 ICF flange	22504
8B1-0010-882	M-350PG-SD/NPT	Pirani Gauge	With 1/8"NPT (male)	22505
8B1-0010-839	M-350PG-SP/N16	Pirani Gauge (w Setpoins)	With NW16 flange	22506
8B1-0010-840	M-350PG-SP/N25	Pirani Gauge (w Setpoins)	With NW25 flange	22507
8B1-0010-841	M-350PG-SP/P15	Pirani Gauge (w Setpoins)	For ϕ 15 gauge port	22508
8B1-0010-842	M-350PG-SP/P18	Pirani Gauge (w Setpoins)	For ϕ 18 gauge port	22509
8B1-0010-965	M-350PG-SP/C34	Pirani Gauge (w Setpoins)	With ϕ 34 ICF flange	22510
8B1-0010-916	M-350PG-SP/NPT	Pirani Gauge (w Setpoins)	With 1/8"NPT (male)	22511
8B1-0010-843	M-350PG-RS/N16	Pirani Gauge (RS485)	With NW16 flange	22512
8B1-0010-844	M-350PG-RS/N25	Pirani Gauge (RS485)	With NW25 flange	22513
8B1-0010-845	M-350PG-RS/P15	Pirani Gauge (RS485)	For ϕ 15 gauge port	22514
8B1-0010-846	M-350PG-RS/P18	Pirani Gauge (RS485)	For ϕ 18 gauge port	22515
8B1-0011-179	M-350PG-RS/C34	Pirani Gauge (RS485)	With ϕ 34 ICF flange	22516
8B1-0011-061	M-350PG-RS/NPT	Pirani Gauge (RS485)	With 1/8"NPT (male)	22517
8B1-0014-339	MP1/N16	Pirani Gauge Sensor	With NW16 flange	22527
8B1-0014-352	MP1/N25	Pirani Gauge Sensor	With NW25 flange	22528
8B1-0014-387	MP1/C34	Pirani Gauge Sensor	With ϕ 34 ICF flange	22529
8B1-0014-657	MP1/NPT	Pirani Gauge Sensor	With 1/8"NPT (male)	22530
8B1-0014-612	MP1/P15	Pirani Gauge Sensor	For ϕ 15 gauge port	22531
8B1-0014-613	MP1/P18	Pirani Gauge Sensor	For ϕ 18 gauge port	22532
8B1-0010-971	M-351PG-SP/N16	Pirani Gauge (Nickel filament)	With NW16 flange	22665
8B1-0011-008	M-351PG-SP/N25	Pirani Gauge (Nickel filament)	With NW25 flange	22666
8B1-0015-292	MP2/N16	Pirani Gauge Sensor (Nickel filament)	With NW16 flange	22668
8B1-0015-370	MP2/N25	Pirani Gauge Sensor (Nickel filament)	With NW25 flange	22669

Cold Cathode Gauge

M-370CG

Summary

A solid cold cathode gauge (cold cathode ionization gauge) that does not use a hot filament.

Compatible with a wide range of processes and achieves stable pressure measurement in high vacuum conditions.

Features

- Uses a unique light trigger mechanism that reduces measurement stoppages
- Handles a wide range of processes
- Low maintenance costs
- Maintenance only requires part replacement

Specifications

Type	Cold Cathode Gauge	
	M-370CG-SP Type with set point	M-370CG-RS RS485 Type*1
Pressure measurement range	1×10 ⁻⁷ ~ 1×10 ⁰ Pa	
Accuracy	±30% : 1×10 ⁻⁶ ~ 1×10 ⁰ Pa	
Repeatability	±5% : 1×10 ⁻⁶ ~ 1×10 ⁰ Pa	
Input voltage	DC+15 ~ 30 V	
Power consumption	2.4 W	
Analog output	0 ~ 10 V	—
Set point	2 Contact Output (1A 30V DC)	
Interface	—	RS485
I/O connector	D-sub 9 pin (Pin type)	
Maximum cable length	300 m (1 mm ²) ※2	
Operating Temperature	5 ~ 55°C	
Storage Temperature	-20 ~ 70°C (at no operation)	
Sensor allowable temperature range	150°C MAX (Without electronics)	
Suitable sensor	CC1	
Sensor material (main component)	Electrode : Mo, Insulator : Al ₂ O ₃ Case : Stainless steel	
Dimensions	110×50×50 mm (NW25)	
Flange shape and weight	NW25 (485 g) , NW40 (501 g) φ 70ICF (735 g)	
Conformity	CE marking , RoHS , IP40	

※1 The RS485 type is not compatible with the M-601/603GC display.

※2 The maximum length of the gauge cable is 100m when connecting an M-601/603GC display unit.

Note: The ignition of CC gauge may be delayed significantly under conditions of high partial pressure of active gas such as H₂ and O₂ or large volume use of these gases. Please contact us when using the gauge under conditions of these gases.

Ordering information

Parts Number	Model	Description	Remarks	Code
8B1-0011-288	M-370CG-SP/N25	Cold Cathode Gauge	With NW25 flange	22806
8B1-0011-289	M-370CG-SP/N40	Cold Cathode Gauge	With NW40 flange	22807
8B1-0011-290	M-370CG-SP/C70	Cold Cathode Gauge	With φ 70 ICF flange	22808
8B1-0011-291	M-370CG-RS/N25	Cold Cathode Gauge (RS485)	With NW25 flange	22809
8B1-0011-292	M-370CG-RS/N40	Cold Cathode Gauge (RS485)	With NW40 flange	22810
8B1-0011-293	M-370CG-RS/C70	Cold Cathode Gauge (RS485)	With φ 70 ICF flange	22811
8B1-0018-759		M-361CP/370CG Maintenance kit	Pole piece, Mesh	22790

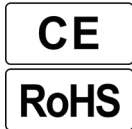
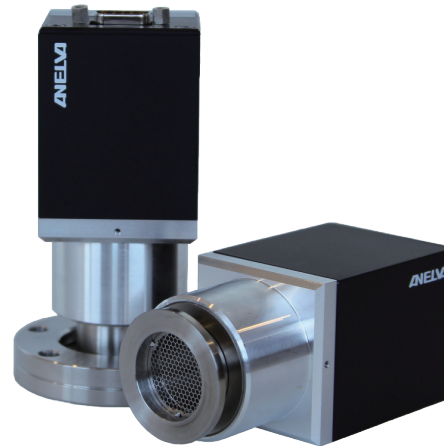

Dimensions diagram

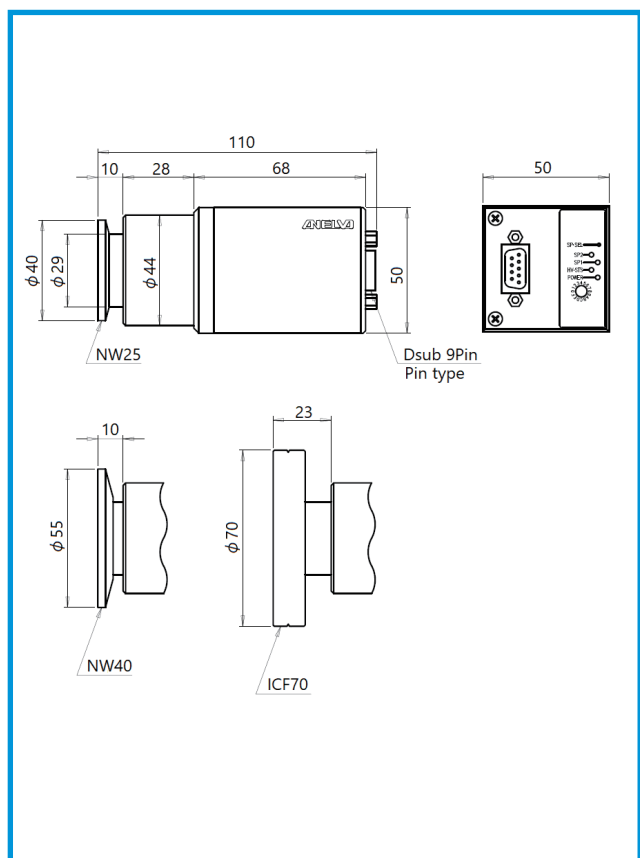

Cold Cathode Pirani Gauge

M-361CP

Summary

A combination gauge that combines a solid cold cathode gauge (cold cathode ionization gauge) and a Pirani gauge.

One single unit that can provide stable pressure measurement over a wide pressure range, from atmospheric pressure to high vacuum.

System cost is reduced with a dual-purpose device.

Features

- Uses a unique light trigger mechanism that reduces measurement stoppages
- Handles a wide range of processes
- Reduce costs with a dual-purpose device
- Low maintenance costs
- Maintenance only requires part replacement

Specifications

Type	Cold Cathode Pirani Gauge	
	M-361CP-SP Type with set point	M-361CP-RS S485 Type *1
Pressure measurement range	1×10 ⁻⁷ ~ 1×10 ⁵ Pa	
Accuracy	±30% : 1×10 ⁻⁶ ~ 1×10 ⁴ Pa ±50% : 1×10 ⁴ ~ 1×10 ⁵ Pa	
Repeatability	±5% : 1×10 ⁻⁶ ~ 1×10 ⁴ Pa	
Input voltage	DC+15 ~ 30 V	
Power consumption	2.4 W	
Analog output	0 ~ 10 V	—
Set point	2 Contact Output (1A 30V DC)	
Interface	—	RS485
I/O connector	D-sub 9 pin (Pin type)	
Maximum cable length	300 m (1 mm ²) ※2	
Zero points adjustment	Push switch	
Operating Temperature	5 ~ 55°C	
Storage Temperature	-20 ~ 70°C (at no operation)	
Sensor allowable temperature range	150°C MAX (Without electronics)	
Suitable sensor	CP2	
Sensor material (main component)	Filament : W, Electrode : Mo Insulator : Al ₂ O ₃ , Case : Stainless steel	
Dimensions	110×50×50 mm (NW25)	
Flange shape and weight	NW25 (485 g), NW40 (501 g) φ 70ICF (735 g)	
Conformity	CE marking, RoHS, IP40	

※1 The RS485 type is not compatible with the M-601/603GC display.

※2 The maximum length of the gauge cable is 100m when connecting an M-601/603GC display unit.

Note: The ignition of CC gauge may be delayed significantly under conditions of high partial pressure of active gas such as H₂ and O₂, or large volume use of these gases. Please contact us when using the gauge under conditions of these gases.

Ordering information

Parts Number	Model	Description	Remarks	Code
8B1-0011-263	M-361CP-SP/N25	Cold Cathode Pirani Gauge	With NW25 flange	22800
8B1-0011-264	M-361CP-SP/N40	Cold Cathode Pirani Gauge	With NW40 flange	22801
8B1-0011-265	M-361CP-SP/C70	Cold Cathode Pirani Gauge	With φ 70 ICF flange	22802
8B1-0011-266	M-361CP-RS/N25	Cold Cathode Pirani Gauge (RS485)	With NW25 flange	22803
8B1-0011-267	M-361CP-RS/N40	Cold Cathode Pirani Gauge (RS485)	With NW40 flange	22804
8B1-0011-268	M-361CP-RS/C70	Cold Cathode Pirani Gauge (RS485)	With φ 70 ICF flange	22805
8B1-0018-759		M-361CP/370CG Maintenance kit	Pole piece, Mesh	22790

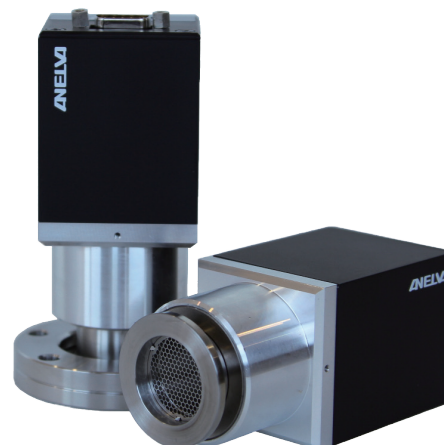

CE

RoHS

Dimensions diagram

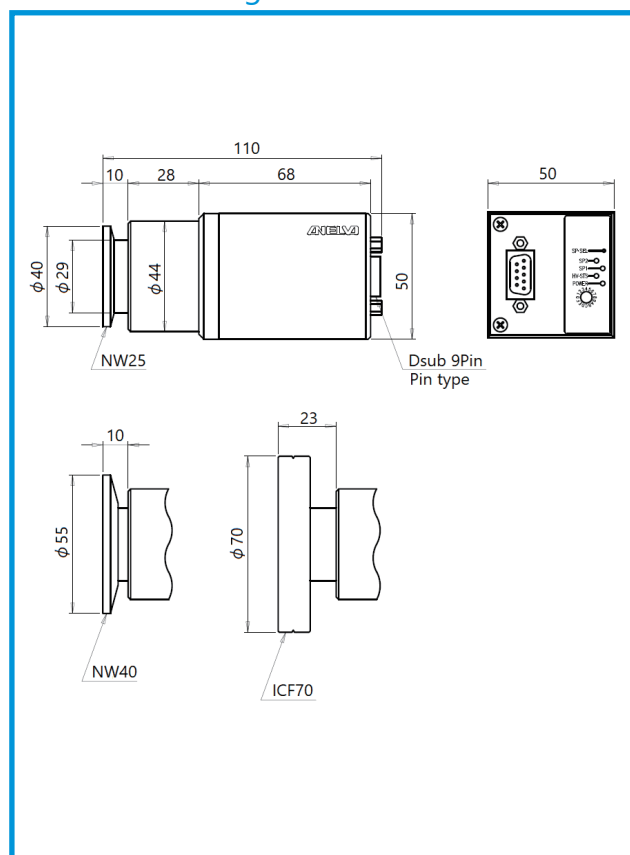

Ion Gauge

M-311HG

CE

RoHS

Summary

A vacuum gauge that uses a miniature B-A gauge (hot cathode vacuum gauge) with a long history of reliability and proven performance, with excellent repeatability and accuracy.

A wide range type that can measure from 10 Pa to high vacuum.

Features

- Wide range pressure measurement
- Trustworthy sensors with proven performance
- High-precision pressure measurement
- Emission current can be set according to the application
- Replaceable measuring sphere



Specifications

Type	Ion Gauge	
	M-311HG-SP Type with set point	M-311HG-RS RS485 type ※1
Pressure measurement range	1×10 ⁻⁷ ~ 10 Pa	
Measuring accuracy	±15% : 1×10 ⁻⁶ ~ 1×10 ⁰ Pa	
Reproducibility	±5% : 1×10 ⁻⁶ ~ 1×10 ⁰ Pa	
Input voltage	DC+20 ~ 28 V	
Power consumption	12 W	
Analog output	0 ~ 10 V	—
Set point	2 Contact Output (1A 30V DC)	
Interface	—	RS485
I/O connector	D-sub 9 pin (Pin type)	
Maximum cable length	300 m (1 mm ²) ※2	
Operational temperature range	5 ~ 50°C	
Storage temperature range	-20 ~ 70°C (at no operation)	
Sensor allowable temperature range	O-ring type: 150°C MAX Metal seal type: 300°C MAX (Without electronics)	
Suitable sensor	Miniature B-A Gauge (MG-2I Series)	
Sensor material (main component)	Filament : Yttria coated iridium Case : SUS304	
Dimensions	144×70×50 mm (NW25)	
Flange shape and weight	NW16 (409 g) , NW25 (423 g) φ 34ICF (428 g) , φ 70ICF (668 g)	
Conformity	CE marking, RoHS, IP40	

Dimensions diagram

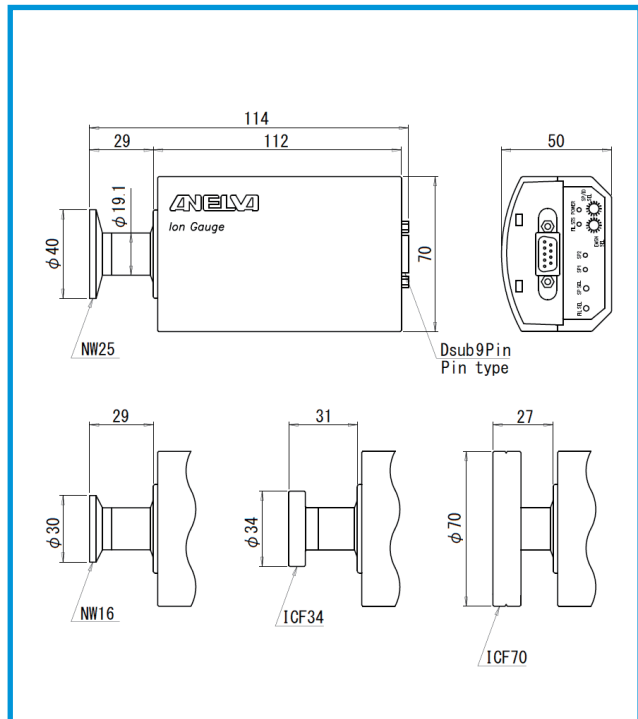

※1 The RS485 type is not compatible with the M-601/603GC display.

※2 The maximum length of the gauge cable is 100m when connecting an M-601/603GC display unit.

Ordering information

Parts Number	Model	Description	Remarks	Code
8B1-0015-826	M-311HG-SP/N16	Ion Gauge	With NW16 flange	22670
8B1-0015-827	M-311HG-SP/N25	Ion Gauge	With NW25 flange	22671
8B1-0015-828	M-311HG-SP/C70	Ion Gauge	With φ 70 ICF flange	22672
8B1-0015-829	M-311HG-SP/C34	Ion Gauge	With φ 34 ICF flange	22673
8B1-0015-830	M-311HG-RS/N16	Ion Gauge (RS485 Type)	With NW16 flange	22674
8B1-0015-831	M-311HG-RS/N25	Ion Gauge (RS485 Type)	With NW25 flange	22675
8B1-0015-832	M-311HG-RS/C70	Ion Gauge (RS485 Type)	With φ 70 ICF flange	22676
8B1-0015-833	M-311HG-RS/C34	Ion Gauge (RS485 Type)	With φ 34 ICF flange	22677
8G1-0505-480	MG-2I/NW16	Miniature B-A Gauge Sensor	With NW16 flange	21163
8B1-0018-082	MG-2I/NW25	Miniature B-A Gauge Sensor	With NW25 flange	21164
8G1-0505-482	MG-2I/ICF34	Miniature B-A Gauge Sensor	With φ 34 ICF flange	21165
8B1-0018-045	MG-2I/ICF70	Miniature B-A Gauge Sensor	With φ 70 ICF flange	21166

Crystal Ion Gauge

M-338MX

Summary

A combination gauge that uses a crystal gauge with excellent repeatability and precision for measurement in low vacuum conditions, as well as a miniature B-A gauge (hot cathode vacuum gauge) with a long history of reliability and proven performance in high vacuum conditions.

A single unit that can provide high-precision measurement over a wide pressure range, from atmospheric pressure to high vacuum.

System cost is reduced with a dual-purpose device.

Features

- Reduce costs with a dual-purpose device
- High-precision pressure measurement
- Atmospheric pressure sensor function
- Replaceable sensor

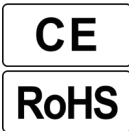

Specifications

Type	Crystal Ion Gauge	
	M-338MX-SP Type with set point	M-338MX-RS RS485 type ^{※1}
Pressure measurement range	4×10 ⁻⁸ ~ 1×10 ⁵ Pa ^{※2 ※3}	
Measuring accuracy	±15% : 1×10 ⁻⁶ ~ 1×10 ¹ Pa ±20% : 5×10 ¹ ~ 1×10 ⁵ Pa (Except 1×10 ⁰ ~ 5×10 ¹ , 1×10 ² ~ 5×10 ³ Pa)	
Reproducibility	±5% : 1×10 ⁻⁶ ~ 1×10 ⁵ Pa	
Input voltage	+20 ~ 28 V DC	
Power consumption	12 W	
Analog output	0 ~ 10 V	—
Set point	2 Contact Output (1A 30V DC)	
Interface	—	RS485
I/O connector	D-sub 9 pin (Pin type)	
Maximum cable length	300 m (1 mm ²) ^{※4}	
Zero points adjustment	Push switch	
Operational temperature range	5 ~ 50°C	
Storage temperature range	-20 ~ 70°C (at no operation)	
Sensor allowable temperature range	150°C MAX (Without electronics)	
Suitable sensor	MX3	
Sensor material (main component)	Crystal Gauge : Quartz resonator B-A gauge Filament : Yttria coated iridium Case : SUS304	
Dimensions	148.5×70×50 mm (NW25)	
Flange shape and weight	NW16 (429 g), NW25 (435 g) NW40 (472 g), φ 70ICF (671 g)	
Conformity	CE marking, RoHS, IP40	

Dimensions diagram

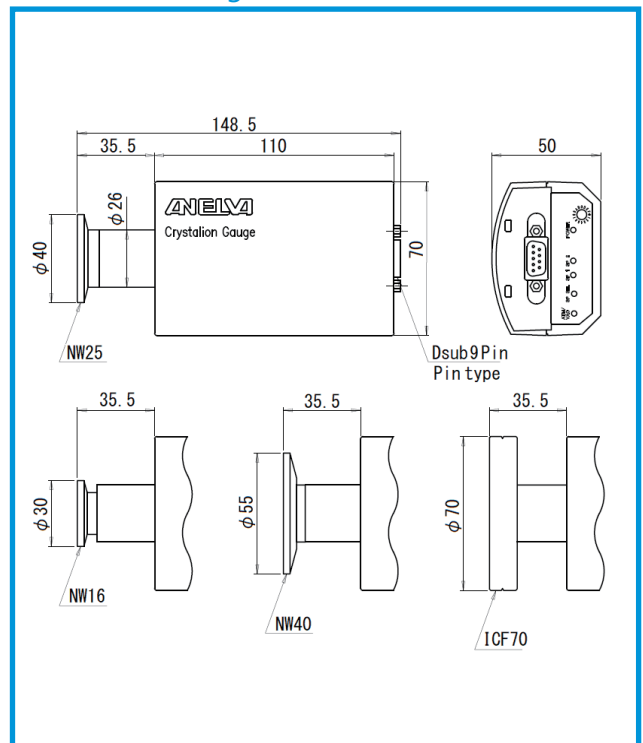

※1 The RS485 type is not compatible with the M-601/603GC display.

※2 "4 × 10⁻⁸ Pa", the lower limit of the pressure measurement range, is the soft X-ray limit of this gauge.

※3 The lower limit pressure for actual measurement is ICF:10⁻⁷ Pa, NW:10⁻⁶ Pa.

※4 The maximum length of the gauge cable is 100m when connecting an M-601/603GC display unit.

Ordering information

Parts Number	Model	Description	Remarks
8B1-30KV-000	M-338MX-SP/N16	Crystal Ion Gauge	With NW16 flange
8B1-30B0-000	M-338MX-SP/N25	Crystal Ion Gauge	With NW25 flange
8B1-30KX-000	M-338MX-SP/N40	Crystal Ion Gauge	With NW40 flange
8B1-30KY-000	M-338MX-SP/C70	Crystal Ion Gauge	With φ 70ICF flange
8B1-30KZ-000	M-338MX-RS/N16	Crystal Ion Gauge (RS485 Type)	With NW16 flange
8B1-30L0-000	M-338MX-RS/N25	Crystal Ion Gauge (RS485 Type)	With NW25 flange
8B1-30L1-000	M-338MX-RS/N40	Crystal Ion Gauge (RS485 Type)	With NW40 flange
8B1-30L2-000	M-338MX-RS/C70	Crystal Ion Gauge (RS485 Type)	With φ 70 ICF flange
8B1-30HV-000	MX3/NW16	Crystal Ion Gauge Sensor	With NW16 flange
8B1-30B2-000	MX3/NW25	Crystal Ion Gauge Sensor	With NW25 flange
8B1-30HX-000	MX3/NW40	Crystal Ion Gauge Sensor	With NW40 flange
8B1-30J1-000	MX3/ICF70	Crystal Ion Gauge Sensor	With φ 70 ICF flange

Display Unit (1 ch/3 ch)

M-601GC / 603GC

CE

RoHS

Summary

The display is compatible with the transducer type vacuum gauge series.

The display is easy to see, greatly improving operability.

Choose between the 1ch type and the 3ch type according to your application.

Features

- Can be connected to all gauges (automatic gauge recognition)
- RS232C interface standard equipped
- Can display 3 channels simultaneously (M-603GC)
- Choose from digital or analog display (M-603GC)
- Trend graph display (M-603GC)



1ch display unit

3ch display unit

3ch display unit Display mode

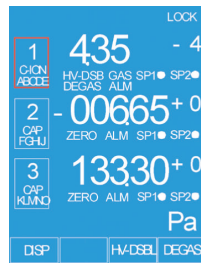

Digital

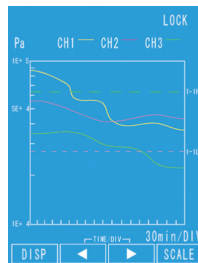

Trend graph

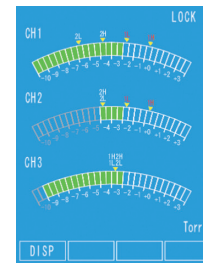

Analog meter

Specification

Type	M-601GC (1 Ch connection type)	M-603GC (3 Ch connection type)
Input voltage	AC90 ~ 250 V 50/60 Hz	
Power consumption	50 VA	100 VA
Operating temperature	5 ~ 50°C	
Storage temperature	-20 ~ 60°C	
Gauge recognition	Auto	
Number of connected channels	1ch	3ch (Simultaneously displayable)
Connected gauge (-RS type excluded)	<ul style="list-style-type: none"> • Capacitance gauge • Pirani gauge • Cold cathode gauge • Cold cathode pirani gauge • Ion gauge • Crystal ion gauge 	
Set point	2 points	2 points/ ch
Analog output	1	1 / ch
Recorder output	1	1/ ch
Communication function	RS232C	
Dimensions	84×106.3×212 mm	128.5×106.3×212 mm
Weight	1.3 kg	2.1 kg
Display	Backlit LCD	Color TFT LCD
Conformity	CE marking, RoHS, IP30	

Dimensions diagram

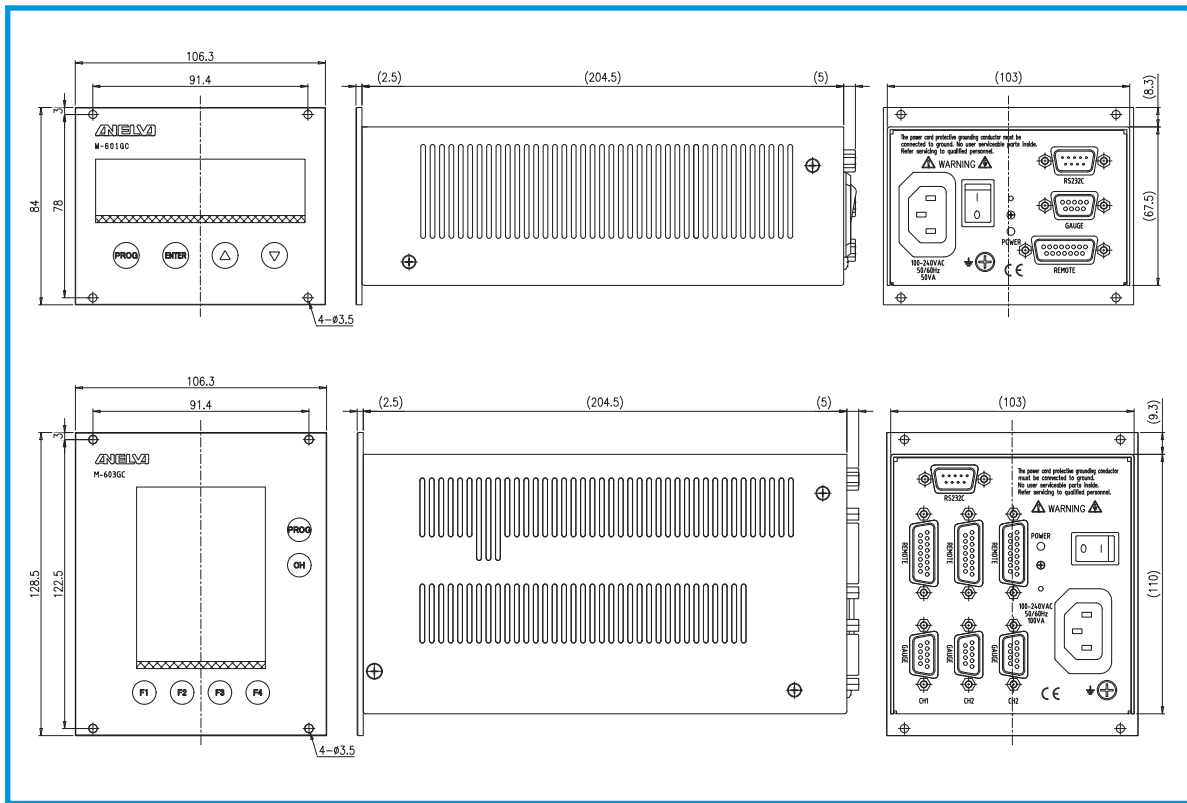

Ordering information

Part Number	Model name	Description	Remarks	Code
8B1-0014-655	M-601GC	Display Unit (1CH)	No external control connector, AC cable	22563
8B1-0014-656	M-603GC	Display Unit (3CH)	No external control connector, AC cable	22564
8A1-0934-611	601-005-M	Gauge Cable for M-601/603GC (5m)		22467
8A1-0934-612	601-010-M	Gauge Cable for M-601/603GC (10m)		22468
8A1-0934-613	601-015-M	Gauge Cable for M-601/603GC (15m)		22469
8A1-0402-633		Connector for Gauge (D-Sub9P)		22570
8A1-0402-631		Power Cable for M601/603GC	3 m	22571
8D1-0006-055		SCREWDRIVER(PLASTICS)	Ordering unit 10E	22572
8A1-0402-634		I/O Connector for M-601/603GC (D-Sub15P)		22573

Canon CANON ANELVA CORPORATION



Component Sales Dept. of Head Office

5-1 Kurigi 2-chome, Asao-ku, Kawasaki-shi, Kanagawa 215-8550, Japan

TEL : +81-44-980-3503 FAX : +81-44-986-4038

Canon U.S.A., Inc

3300 North First Street San Jose, CA 95134, U.S.A.

TEL : +1-408-468-2000 FAX : +1-408-468-2343

Canon Europa N.V.

Bovenkerkerweg 59, 1185 XB Amstelveen, The Netherlands

TEL : +31-20-545-8545 FAX : +31-20-545-8222

Canon Semiconductor Engineering Korea Inc.

49,Dosijiwon 1-gil, Godeok-myeon, Pyeongtaek-si, Gyeonggi-do, Republic of Korea

TEL : +82-31-616-2020 FAX : +82-31-616-2023

Canon Semiconductor Equipment Taiwan, Inc.

9F-2, No.25, Pu-Ding Road, Hsinchu, 300, Taiwan

TEL : +886-3-668-6600 FAX : +886-3-668-6969

Canon Singapore Pte. Ltd.

1 Fusionopolis Place #14-10, Galaxis Singapore 138522

TEL : +65-6799-8888 FAX : +65-6271-4226

Canon Optical Industrial Equipment (Shanghai) Inc.

3-4F, South Wing, Building 5, Innovation Galaxy, No.210 Wenshui Rd,
Jing'an District, Shanghai 200072, China

TEL : +86-21-2316-3200 FAX : +86-21-2316-3222

Canon ANELVA Corporation is constantly improving its products, hence specifications are subject to change without notice.

<https://anelva.canon/en/>